

An original SteelCrete I common stud with punched-out tabs which are key for embedment in thin shell concrete.



New SteelCrete III common stud and snap-in clip strip insert using rebar for additional reinforcing.

## SteelCrete Inc. Boasts Multiple Application Possibilities after Construction Specifications Institute Adopts Thin Shell Category

By Tony Ruiz, Inventor and Owner  
SteelCrete, Inc.

LOS ANGELES, CA—The Construction Specifications Institute (CSI) has revised its Master Format numbers and titles for the Thinshell building industry, according to the CSI and Tony Ruiz who worked on this project for some time. The number and title 03 48 33 Precast Pre-Framed Concrete Panels is applicable to Thinshell building systems produced since about 1980 when Ruiz began using a first generation technology, then Metalcrete, now Steelcrete (SC I also known as Hi-Tech Tilt).

Others have populated this perhaps fastest-growing segment of the architecture, engineering and construction (AEC) industry where otherwise common light gage metal framing (a.k.a. metal studs) is modified and partially embedded in thin conventional (1½" to 2") concrete. This physical and chemical union between the two readily available standard materials is known as a composite connection where the concrete bonds to the galvanized metal. Numerous methods used to form the physical connection including several generations of Ruiz' SteelCrete, MetalCrete (also a Ruiz invention) and several other systems. All are in the process of obtaining ICC ESRs but are not required because standard, straightforward engineering to meet building requirements is now more evidenced by the new CSI designation.

The building system technology is used for precast architectural concrete floors, walls and roofs produced in precast plants, on site and now cast-in-place using new patent pending technology by Ruiz. Patents were issued in the U.S. and Mexico with other foreign patents pending.

### Composite Thinshell History

About 30 years ago a new method was developed for walls, floors and roofs called "Thinshell," where light gage metal framing and conventional thin (1½") concrete when it was discovered that concrete bonds to galvanized metal resulting in a whole that exceeded the sum of its parts. This is known as "composite" action.

Initially, metal studs were cold-rolled with a deformed flange lip that was "wet-embedded" in concrete placed face down and produced as tilt-up on site or precast off site. Track was later added to increase shear values and remains as standard practice today in all this type system. Reinforcing mesh was wired to the deformed lip to hold it in its proper placement in the thin concrete. Codes later required the change from the wet-embed method to the placement of concrete around the metal framing between studs and track.

Shortly after this, a major equipment manufacturer developed an energy-efficient metal stud design that results in framing with the energy efficiency of wood framing with web punch-outs that result in a "truss design" product that is stronger and lighter than conventional studs and usually allows a reduction in gage (metal thickness). This product is produced in the composite form as well as standard-type studs for all applications that utilize conventional studs.



A 60'x55' SteelCrete wall panel erected in Laredo, TX.

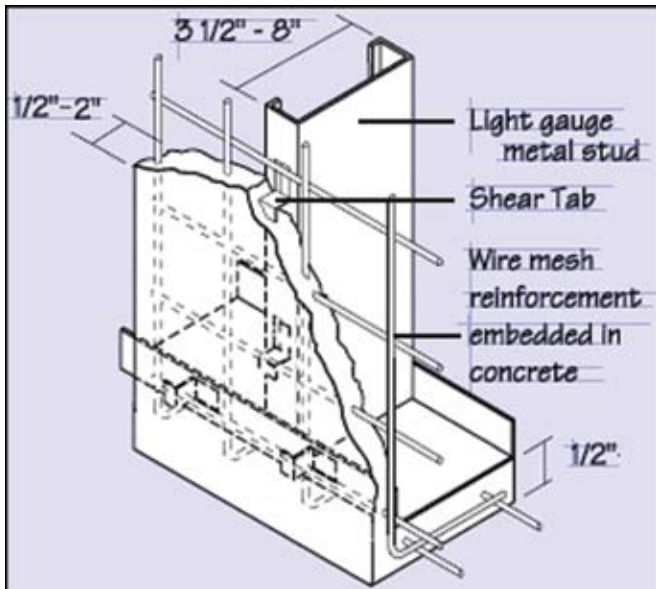
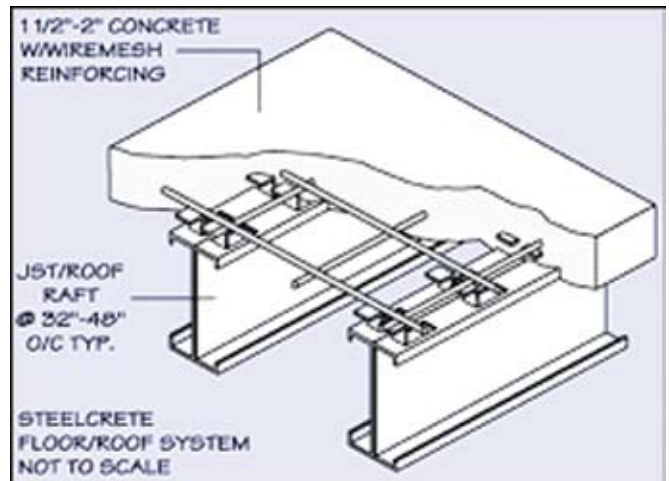

Illustration shows composite SteelCrete II wall section.



Typical SteelCrete floor and roof application.

A later development introduced another energy-efficient stud design with triangle shaped flanges first used in place of standard metal studs. This development later temporarily teamed up with the early “strip” design for a composite application but this reportedly is no longer an option.

In 1991 a new method was developed called MetalCrete (a.k.a. MetalStudCrete) where a punched metal strip with embedment “fingers” is screwed on metal stud webs and track flanges, but relies on the screws and friction for its connection to the concrete. Reinforcing mesh must be “chaired up” from the casting surface because the fingers are not compatible with the mesh spacing. These 4' long strips are shipped on pallets from the fabricator’s shop to the precaster or job site, and are somewhat difficult to separate from the nested state.

A punched “tab” method was developed in 1999 where standard metal stud & track product was shipped to a shop where an expensive punch press stamped out these “L” or



A 70' panel is lifted into place in Laredo, TX by a SteelCrete licensee.

“J-Bolt” shaped 6" o.c. tabs which provided the embedment. Then the modified studs and track are shipped to the job site. Again, the tab spacing was incompatible with the wire mesh, so it also must be chaired up. This system’s inventor later learned a 50% strength increase resulting from the closer tab spacing and filed for a patent. A former partner designed a trailered



This 2008 newest concrete tilt-up house stands adjacent to the 1918 Raymond House, the oldest concrete tilt-up house and a national historical landmark by architect Irving Gill.

punch press that is pulled or otherwise transported to the job site where standard studs and track are punched.

The advantages were short-lived when in 2003 a “V” stamped strip was invented similar to MetalCrete where these perforated V on 4' strips are inserted through the inside of the flange of pre-punched or site-punched metal studs and track and snaps in place without the use of fasteners. An inexpensive, portable punch press is used to punch the slots. A heavy-gauge wire or small diameter rebar can be passed through the perforations for optional added strength that the reinforcing mesh can be attached to. The nested strips are shipped on pallets and easily separated. This system provides the strongest, cheapest, fastest connection of the prior strip method.

These are some random photos of some recent commercial, industrial and residential Thinshell projects, but there is hardly a project Thinshell is not well suited for, competing favorably with wood and metal framing with exterior finish, concrete block, tilt-up, SIPs, ICF, concrete sandwich panels and the virtual flood of new and innovative building systems and materials usually found within the pages of *Automated Builder Magazine*.

For more information on SteelCrete Inc. contact Tony Ruiz at 951.541.6494 or circle Reader Service No. \_\_.